

Drawing name: M:\Engineering Services\Engineering Design Projects\RESOURCE References\WCC Standard Drawings\SD1-4.dwg (28 May, 2024)

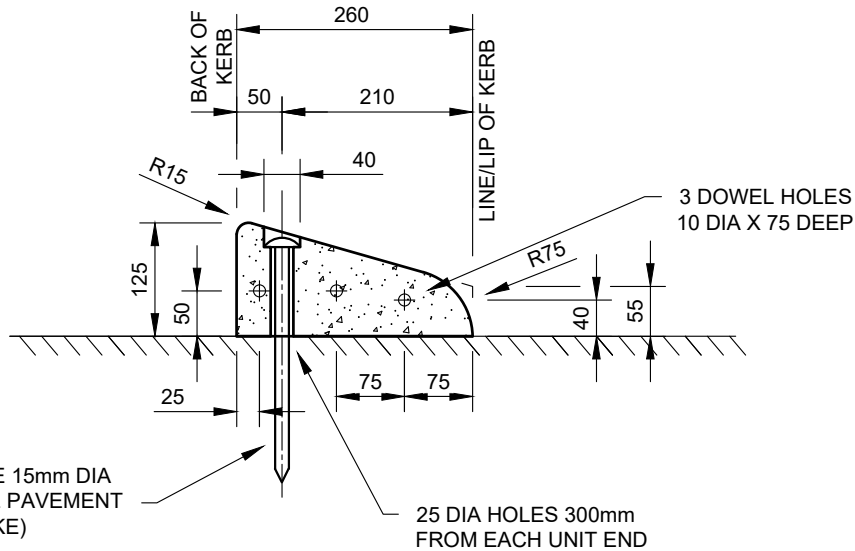

### SPIKED BARRIER KERB (PRE-CAST)

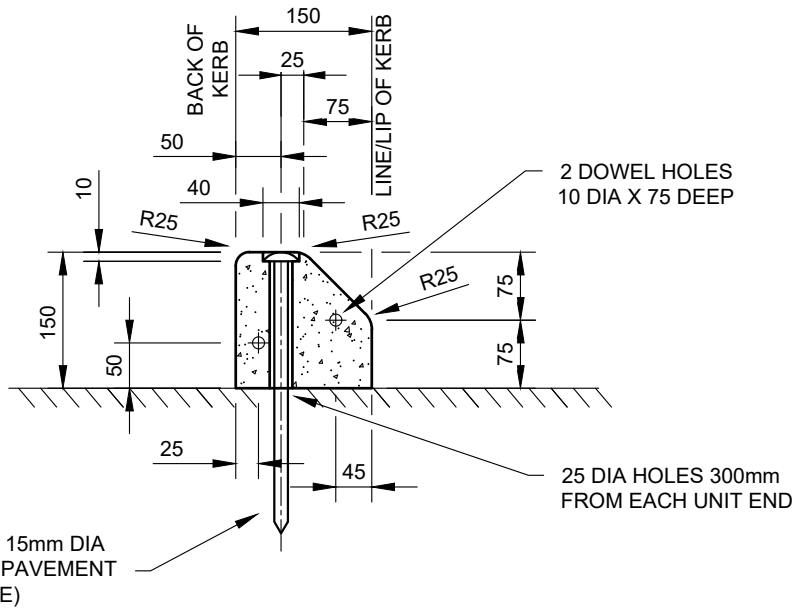

### SPIKED SEMI MOUNTABLE KERB (PRE-CAST)

**NOTES:**

1. SPIKES TO BE HOT DIPPED GALVANISED.
2. CONCRETE SHALL BE NORMAL CLASS N25 COMPLYING WITH THE REQUIREMENTS OF AS 1379. REFER TO WCC SPEC 703 FOR REQUIREMENTS OF CONCRETE TO BE USED IN EXTRUSION MACHINES.
3. PRE-CAST UNITS SHALL HAVE WEIGHT IMPRINTS FOR OH&S MANUAL HANDLING PURPOSES. THE LIFTING SHALL BE 25mm MIN.
4. PRE-CAST UNITS ARE TO HAVE LIFTING HOLES AS PER THE REQUIREMENTS OF AS 3996.
5. POINTED STEEL SPIKE 15mm DIA x 300mm LONG (DRILL PAVEMENT BEFORE DRIVING SPIKE).
6. ALL DIMENSIONS IN MILLIMETRES UNLESS OTHERWISE SHOWN.
7. SPIKED KERBS TO BE CONCRETE UNLESS OTHERWISE APPROVED BY COUNCIL.

REV	AMENDMENTS	APPROVAL	DATE
B	MINOR DRAFTING MODIFICATIONS		19-06-07
C	UPDATED TO REFLECT CURRENT STANDARDS	M.BRIGANDI	21-05-24

<b>KERB PROFILES</b> CONCRETE SPIKED KERBS		CAD FILE: SD1-4.DWG
		DRAWN DATE: FEB 2024
		REVISION: C
		DRAWING NO.: <b>SD1-4</b>
45 PRINCES HIGHWAY WERRIBEE, VIC 3030		TEL: 1300 023 411 wyndham.vic.gov.au

GENERAL NOTES: -DRAWINGS ARE NOT TO SCALE.  
 -ALL MEASUREMENTS ARE IN MILLIMETERS UNLESS OTHERWISE STATED.  
 -FOR UP TO DATE DRAWINGS PLEASE CHECK WYNDHAM CITY COUNCIL WEBSITE.  
 -ALL STANDARD DRAWINGS TO BE USED IN CONJUNCTION WITH SD1-1 (STANDARD DRAWINGS CONDITIONS OF USE).