

Drawing name: M:\Engineering Services\Engineering Design Projects\RESOURCE References\WCC Standard Drawings\SD2-3.dwg (28 May, 2024)

125mm THICK N25 CONCRETE PATH WITH SL72 MESH 50mm TOP COVER. MESH TO HAVE 50mm COVER TO ALL EDGES

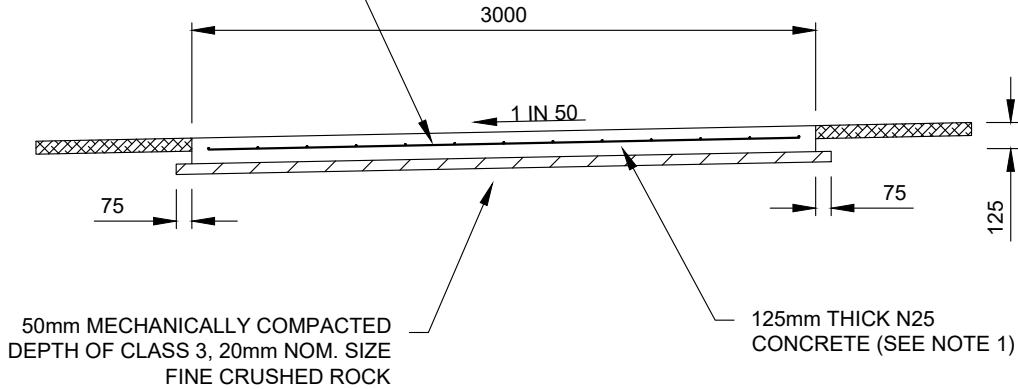

SHARED PATH
2500mm MINIMUM WIDTH IN
CONSTRAINED LOCATIONS

NOTES :

1. CONCRETE STRENGTH IS 25 MPa AT 28 DAYS.
2. TIE BARS TO BE INSTALLED AT 400mm MAXIMUM CENTRES, WITH 4 BARS MINIMUM, COMMENCING 150mm FROM EDGE.
3. COUNCIL'S PRAM CROSSING DETAIL TO BE USED AT ROADWAYS (REFER TO SD3-1).
4. SHARED PATH TO HAVE 30mm DEEP SAWCUT JOINTS AT 3m CENTRES (NO TOOLED JOINTS) AND EXPANSION JOINTS AT 12m MAXIMUM CENTRES AND ONE BAY EITHER SIDE OF VEHICLE CROSSINGS.
5. CONCRETE TO BE LIGHT BROOM FINISHED WITH EDGE AND JOINTS NEATLY TOOLED AFTER THE BROOM IS APPLIED.
6. ALL FINISHED SURFACES TO COMPLY WITH AS 4586 SLIP RESISTANT CLASSIFICATION OF NEW PEDESTRIAN SURFACE MATERIAL.
7. ANY EXPOSED AGGREGATE SURFACE FINISH IS TO BE ACHIEVED BY SANDBLASTING AFTER AT LEAST 48 HOURS CURING TIME.
8. N12mm DIAMETER DEFORMED BARS AT 300mm CENTRES TO JOIN OLD CONCRETE TO NEW WHEN REINSTATING BROKEN FOOTPATH OR AS DIRECTED BY COUNCIL OFFICER.
9. THE USE OF COLOURED CONCRETE MUST BE APPROVED BY COUNCIL. MINIMUM STRENGTH OF COLOURED CONCRETE TO BE 32 MPa.
10. SHARED PATHS TO BE 2500mm IN WIDTH MINIMUM. REFER TO APPROVED CONSTRUCTION PLAN FOR ACTUAL WIDTH.
11. WHERE SHARED PATH IS ALSO USED AS A MAINTENANCE ACCESS TRACK, REFER TO SD4-5 FOR CONCRETE, REINFORCEMENT AND BEDDING SPECIFICATIONS.
12. ALL DIMENSIONS IN MILLIMETRES UNLESS OTHERWISE SHOWN.

REV	AMENDMENTS	APPROVAL	DATE
B	EDITED NOTES 1-3. MINOR DRAFTING MODIFICATIONS		19-06-07
C	ADDED NOTE 9		01-09-09
D	EDITED GRADING & MESH		05-04-13
E	UPDATED TO REFLECT CURRENT STANDARDS	M.BRIGANDI	21-05-24

**SHARED PATH
(ALL LOCATIONS)**



45 PRINCES HIGHWAY
WERRIBEE, VIC 3030

TEL: 1300 023 411
wyndham.vic.gov.au

CAD FILE: SD2-3.DWG
DRAWN DATE: FEB 2024
REVISION: E
DRAWING NO.: SD2-3

GENERAL NOTES: -DRAWINGS ARE NOT TO SCALE.
-ALL MEASUREMENTS ARE IN MILLIMETERS UNLESS OTHERWISE STATED.
-FOR UP TO DATE DRAWINGS PLEASE CHECK WYNDHAM CITY COUNCIL WEBSITE.
-ALL STANDARD DRAWINGS TO BE USED IN CONJUNCTION WITH SD1-1 (STANDARD DRAWINGS CONDITIONS OF USE).