

SUPPLIER: DRAFFIN OR APPROVED SIMILAR.
 PRODUCT CODE: 88957 KIAMA DRINKING FOUNTAIN

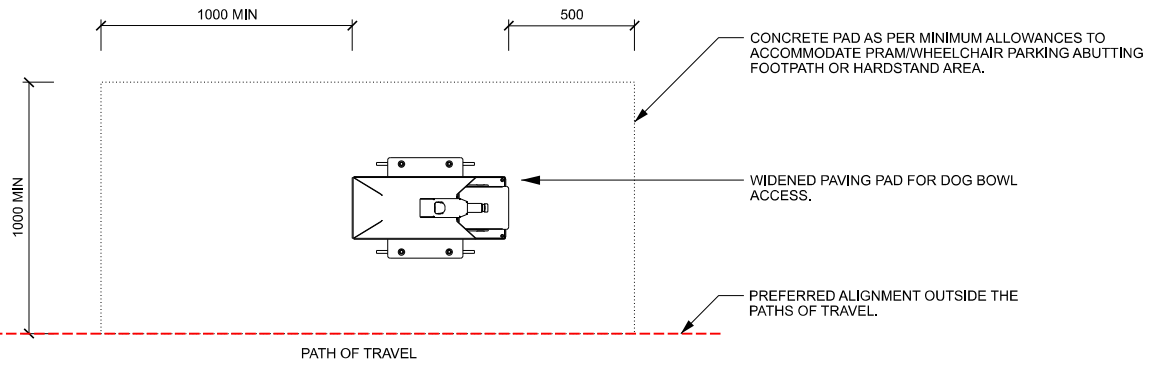

4 DRINKING FOUNTAIN PLAN
 TYPICAL PLAN 1:20

Fittings & Fixtures Schedule					
Reference images	Item	Model/Details	Material	Notes	Alternative
To comply with Australian Standards (AS1428.1)					
	Dog Bowl		Stainless Steel	Refer to finishes schedule for fixing finish. All fixings to be same treatment.	N/A
	Bottle Refill Bubbler		Stainless Steel	Refer to finishes schedule for fixing finish. All fixings to be same treatment.	N/A

Finishes Schedule			
Item	Material	Finish	Alternative Finish
Body	Stainless Steel	Preferred Finish: Brush finish, Electropolished.	N/A
Fixings	Stainless Steel	All fixings to be stainless steel. All exposed fixings to be capped.	N/A
Ground Surface	Hardstand Area to match minimum dimensions shown on plans.	Minimum plain grey concrete with medium broom finish or to match other hardstand surfaces within scope of project works.	

NOTE: ALL CHANGES TO COUNCIL'S PREFERRED FINISHES TO BE SHOWN IN RED FOR COUNCIL APPROVAL.

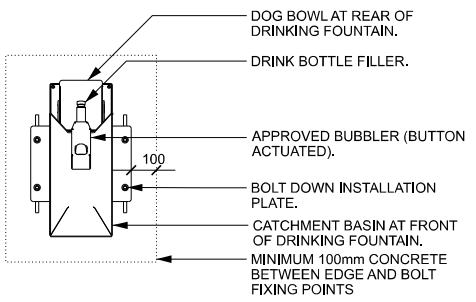

1 DRINKING FOUNTAIN
 TYPICAL PLAN 1:20

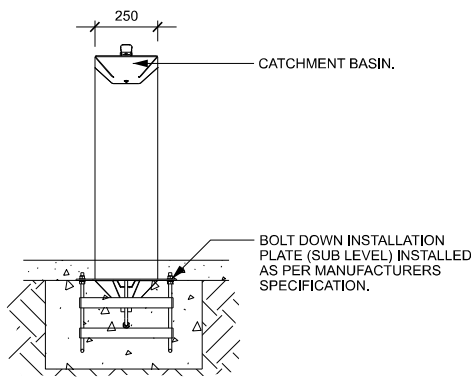

2 DRINKING FOUNTAIN
 TYPICAL FRONT ELEVATION 1:20

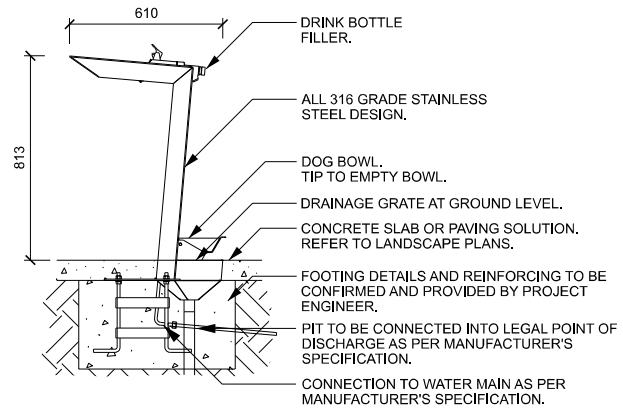

3 DRINKING FOUNTAIN
 TYPICAL SIDE ELEVATION 1:20

REV.	DESCRIPTION	DATE	DRN	CHKD
1	PRELIMINARY	08.09.23	E.B.	R.D.
2	PRELIMINARY	01.11.23	S.M.	R.D.
3	COUNCIL ISSUE	12.07.24	M.M.	R.D.

NOTES

- ALL MEASUREMENTS ARE IN MILLIMETRES UNLESS OTHERWISE STATED.
- REFER WYNDHAM CITY COUNCIL WEBSITE TO ENSURE DRAWINGS ARE THE LATEST REVISION.
- DRAWINGS ARE CONCEPT ONLY AND NOT SPECIFIC TO ANY SITE OR SITE CONDITIONS.
- DRAWINGS CONTAIN TYPICAL ENGINEERING DETAIL FOR INFORMATION ONLY AND WILL REQUIRE PROJECT AND SITE SPECIFIC STRUCTURAL ENGINEERING AND OR SHOP DRAWINGS.
- DRAWINGS WILL BE SUBJECT TO CHANGE THROUGHOUT DESIGN AND CONSTRUCTION PROCESS.
- OVERALL LAYOUT, SIZE AND THEME WILL NOT CHANGE.
- THE DESIGN ASSUMES THAT THE DESIGN WILL BE DEVELOPED AND CONSTRUCTED BY A SUITABLY QUALIFIED CONTRACTOR WITH MINIMUM 10 YEARS RELEVANT INDUSTRY EXPERIENCE.



STANDARD DETAIL - LANDSCAPE
OPEN SPACE FURNITURE
DRINKING FOUNTAIN
 SHEET 1 OF 1

STATUS	COUNCIL ISSUE	NOT FOR CONSTRUCTION
SCALE		DATE
AS SHOWN		08.09.2023
DWG No.		REV
OS 103		3

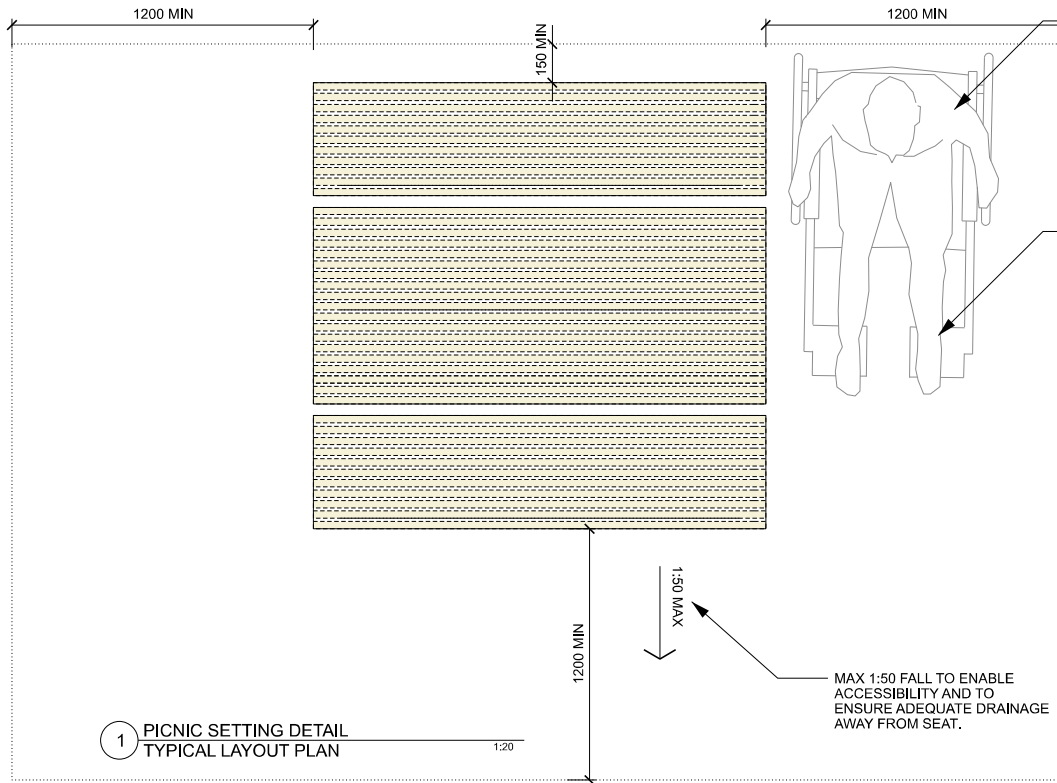

CONCRETE PAD AS PER MINIMUM ALLOWANCES TO ACCOMMODATE PRAM/WHEELCHAIR PARKING ABUTTING FOOTPATH OR HARDSTAND AREA.

DDA COMPLIANT SURFACE.

SUPPLIER: COMMERCIAL SYSTEMS OR APPROVED SIMILAR.
PRODUCT CODE: TM4512-11 MANHATTAN SETTING

Fittings & Fixtures Schedule					
Reference Images	Item	Model/Details	Material	Notes	Alternative
To comply with Australian Standards (AS1428.1)					
	Dolt down fixing		Stainless Steel	Refer to finishes schedule for fixing finish. All fixings to be same treatment.	N/A

Finishes Schedule			
Item	Material	Finish	Alternative Finish
Frame	Mild Steel	Preferred Finish: Monument (black) Powder coated finish.	Alternative Finish: 304 Stainless Steel or alternative powdercoat colour. All alternative finishes and materials are subject to council review and approval.
Battens	Enviroslat Recycled Battens	Preferred Finish: Walnut 40mm x 60mm.	N/A
Fixings	Stainless Steel	All fixings to be stainless steel or galvanised anti-vandal fixings. All exposed fixings to be capped.	N/A
Ground Surface	Hardstand Area to match minimum dimensions shown on plans.	Minimum plain grey concrete with medium broom finish or to match other hardstand surfaces within scope of project works.	

NOTE: ALL CHANGES TO COUNCIL'S PREFERRED FINISHES TO BE SHOWN IN RED FOR COUNCIL APPROVAL.

DETAILS PROVIDED ARE CONSISTENT WITH THE SUPPLIER'S PRODUCT. ALTERNATIVE SUPPLIERS/MANUFACTURERS MAY BE PROPOSED. GENERAL DESIGN THEMES AND MEASUREMENTS SHOULD BE FOLLOWED WHILE ENSURING NO COPYRIGHT LAWS ARE BREACHED. ALL OTHER REQUIREMENTS, MATERIALS, FINISHES AND FIXING METHODS LISTED IN THIS DETAIL NOT ASSOCIATED WITH THE SUPPLIER PRODUCT MUST BE ADHERED TO.

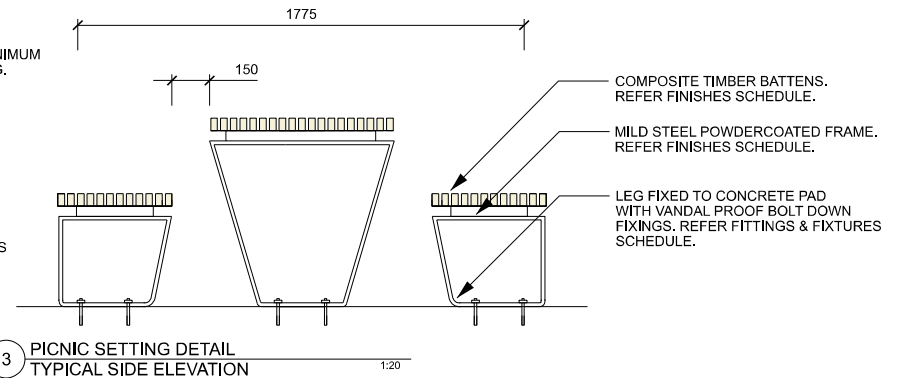
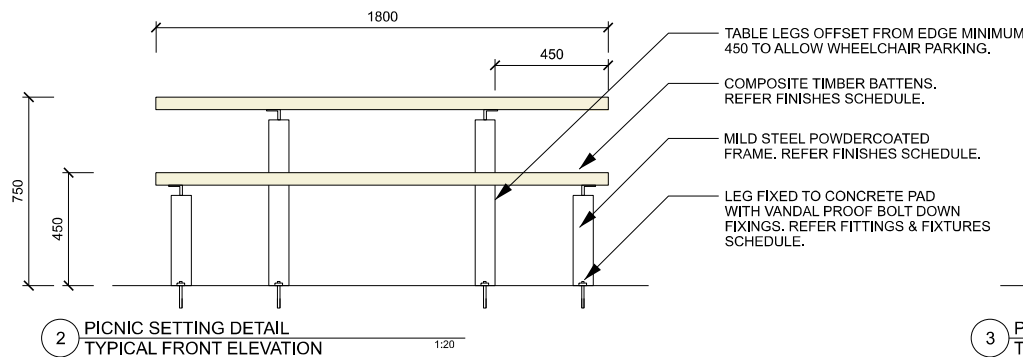

REV.	DESCRIPTION	DATE	DRN	CHKD
1	PRELIMINARY	01.11.23	S.W.	R.D.
2	COUNCIL ISSUE	12.07.24	M.M.	R.D.

NOTES

- ALL MEASUREMENTS ARE IN MILLIMETRES UNLESS OTHERWISE STATED.
- REFER WYNDHAM CITY COUNCIL WEBSITE TO ENSURE DRAWINGS ARE THE LATEST REVISION.
- DRAWINGS ARE CONCEPT ONLY AND NOT SPECIFIC TO ANY SITE OR SITE CONDITIONS.
- DRAWINGS CONTAIN TYPICAL ENGINEERING DETAIL FOR INFORMATION ONLY AND WILL REQUIRE PROJECT AND SITE SPECIFIC STRUCTURAL ENGINEERING AND OR SHOP DRAWINGS.
- DRAWINGS WILL BE SUBJECT TO CHANGE THROUGHOUT DESIGN AND CONSTRUCTION PROCESS.
- OVERALL LAYOUT, SIZE AND THEME WILL NOT CHANGE.
- THE DESIGN ASSUMES THAT THE DESIGN WILL BE DEVELOPED AND CONSTRUCTED BY A SUITABLY QUALIFIED CONTRACTOR WITH MINIMUM 10 YEARS RELEVANT INDUSTRY EXPERIENCE.



STANDARD DETAIL - LANDSCAPE

OPEN SPACE FURNITURE
PICNIC SETTING
SHEET 1 OF 1

STATUS	COUNCIL ISSUE	NOT FOR CONSTRUCTION
SCALE		DATE
AS SHOWN		01.12.2023
DWG No.		REV
OS 104		2

A3

NOTE: MANHATTAN STYLE SEAT IS FOR PARKS.

SUPPLIER: COMMERCIAL SYSTEMS OR APPROVED SIMILAR.
PRODUCT CODE: TM4510 MANHATTAN SEAT

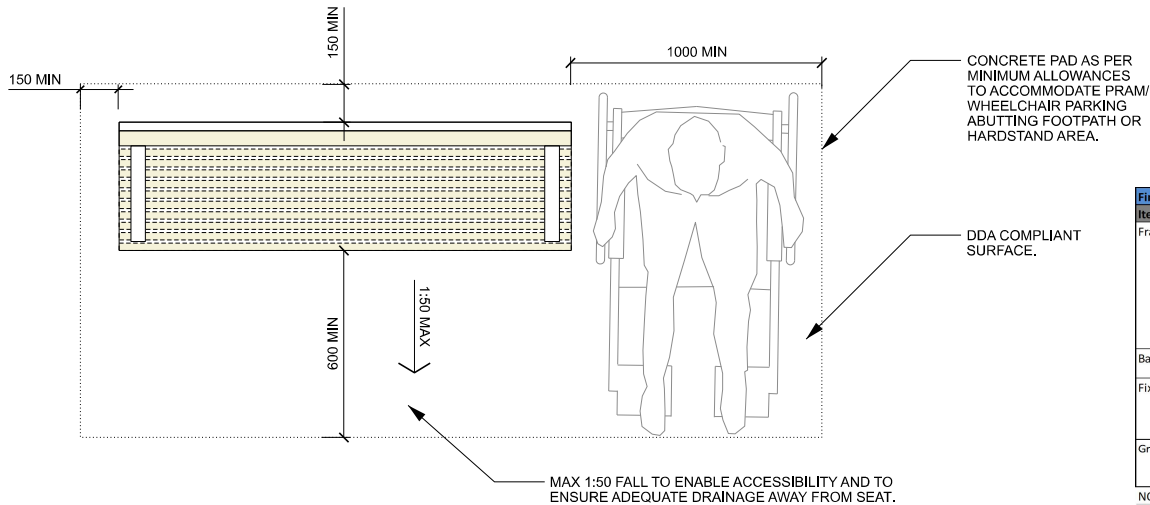

Fittings & Fixtures Schedule					
Reference images	Item	Model/Details	Material	Notes	Alternative
To comply with Australian Standards (AS1428.1)					
	Bolt down fixing		Stainless Steel	Refer to finishes schedule for fixing finish. All fixings to be same treatment.	N/A
	Armrests		Mild steel	Armrest finish to match frame.	N/A

Finishes Schedule			
Item	Material	Finish	Alternative Finish
Frame	Mild Steel	Preferred Finish: Monument (black) Powder coated finish.	Alternative Finish: 304 Stainless Steel or alternative powdercoat colour. All alternative finishes and materials are subject to council review and approval.
Battens	Enviroslat Recycled battens	Preferred Finish: Walnut 40mm x 60mm.	N/A
Fixings	Stainless Steel	All fixings to be stainless steel or galvanised anti-vandal fixings. All exposed fixings to be capped.	N/A
Ground Surface	Hardstand Area to match minimum dimensions shown on plans.	Minimum plain grey concrete with medium broom finish or to match other hardstand surfaces within scope of project works.	

NOTE: ALL CHANGES TO COUNCIL'S PREFERRED FINISHES TO BE SHOWN IN RED FOR COUNCIL APPROVAL.

DETAILS PROVIDED ARE CONSISTENT WITH THE SUPPLIER'S PRODUCT. ALTERNATIVE SUPPLIERS/MANUFACTURERS MAY BE PROPOSED. GENERAL DESIGN THEMES AND MEASUREMENTS SHOULD BE FOLLOWED WHILE ENSURING NO COPYRIGHT LAWS ARE BREACHED. ALL OTHER REQUIREMENTS, MATERIALS, FINISHES AND FIXING METHODS LISTED IN THIS DETAIL NOT ASSOCIATED WITH THE SUPPLIER PRODUCT MUST BE ADHERED TO.

1 SEAT DETAIL TYPICAL LAYOUT PLAN

1:20

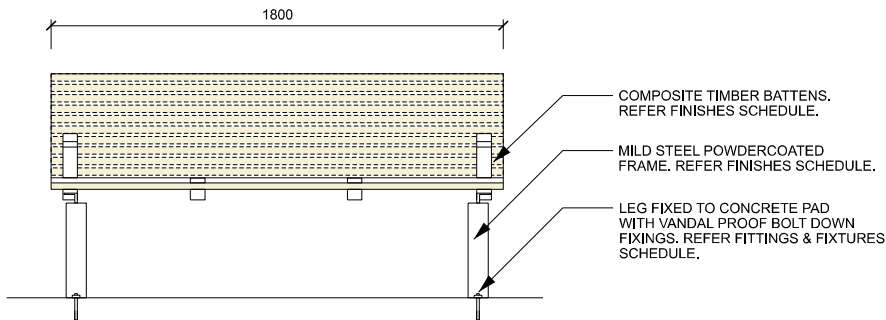

2 SEAT DETAIL TYPICAL FRONT ELEVATION

1:20

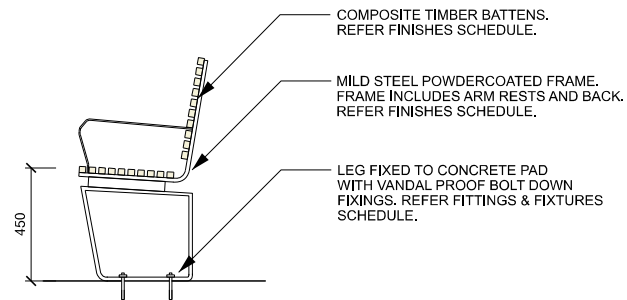

3 SEAT DETAIL TYPICAL SIDE ELEVATION

1:20

REV.	DESCRIPTION	DATE	DRN	CHKD
1	PRELIMINARY	03.08.23	E.B.	R.D.
2	PRELIMINARY	22.11.23	S.M.	R.D.
3	COUNCIL ISSUE	12.07.24	M.M.	R.D.

NOTES

- ALL MEASUREMENTS ARE IN MILLIMETRES UNLESS OTHERWISE STATED.
- REFER WYNDHAM CITY COUNCIL WEBSITE TO ENSURE DRAWINGS ARE THE LATEST REVISION.
- DRAWINGS ARE CONCEPT ONLY AND NOT SPECIFIC TO ANY SITE OR SITE CONDITIONS.
- DRAWINGS CONTAIN TYPICAL ENGINEERING DETAIL FOR INFORMATION ONLY AND WILL REQUIRE PROJECT AND SITE SPECIFIC STRUCTURAL ENGINEERING AND OR SHOP DRAWINGS.
- DRAWINGS WILL BE SUBJECT TO CHANGE THROUGHOUT DESIGN AND CONSTRUCTION PROCESS.
- OVERALL LAYOUT, SIZE AND THEME WILL NOT CHANGE.
- THE DESIGN ASSUMES THAT THE DESIGN WILL BE DEVELOPED AND CONSTRUCTED BY A SUITABLY QUALIFIED CONTRACTOR WITH MINIMUM 10 YEARS RELEVANT INDUSTRY EXPERIENCE.



STANDARD DETAIL - LANDSCAPE

OPEN SPACE FURNITURE
SEAT
SHEET 1 OF 2

STATUS COUNCIL ISSUE NOT FOR CONSTRUCTION

SCALE DATE

AS SHOWN 03.08.2023

DWG No. REV

OS 105A 3 A3

NOTE: ALBERT PARK STYLE SEAT IS FOR SHARED PATH TRAILS.

SUPPLIER: COMMERCIAL SYSTEMS OR APPROVED SIMILAR.
PRODUCT CODE: TM4064 ALBERT PARK SEAT

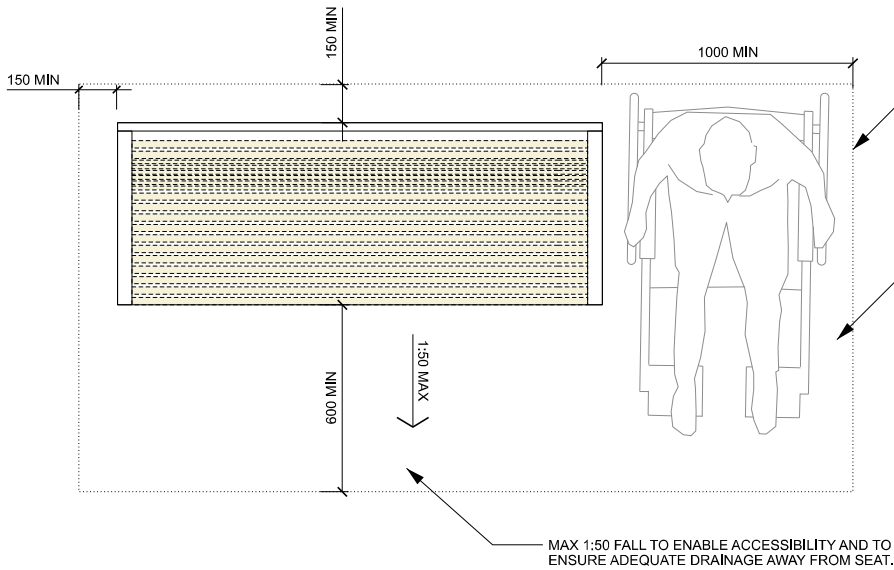

Fittings & Fixtures Schedule					
Reference images	Item	Model/Details	Material	Notes	Alternative
To comply with Australian Standards (AS1428.1)					
	Bolt down fixing		Stainless Steel	Refer to finishes schedule for fixing finish. All fixings to be same treatment.	N/A
	Armrests		Mild steel	Armrest finish to match frame.	N/A

Finishes Schedule			
Item	Material	Finish	Alternative Finish
Frame	Mild Steel	Preferred Finish: Monument (black) Powder coated finish.	Alternative Finish: 304 Stainless Steel or alternative powdercoat colour. All alternative finishes and materials are subject to council review and approval.
Battens	Enviroslat Recycled battens	Preferred Finish: Walnut 40mm x 60mm.	N/A
Fixings	Stainless Steel	All fixings to be stainless steel or galvanised anti-vandal fixings. All exposed fixings to be capped.	N/A
Ground Surface	Hardstand Area to match minimum dimensions shown on plans.	Minimum plain grey concrete with medium broom finish or to match other hardstand surfaces within scope of project works.	

NOTE: ALL CHANGES TO COUNCIL'S PREFERRED FINISHES TO BE SHOWN IN RED FOR COUNCIL APPROVAL.

DETAILS PROVIDED ARE CONSISTENT WITH THE SUPPLIER'S PRODUCT. ALTERNATIVE SUPPLIERS/MANUFACTURERS MAY BE PROPOSED. GENERAL DESIGN THEMES AND MEASUREMENTS SHOULD BE FOLLOWED WHILE ENSURING NO COPYRIGHT LAWS ARE BREACHED. ALL OTHER REQUIREMENTS, MATERIALS, FINISHES AND FIXING METHODS LISTED IN THIS DETAIL NOT ASSOCIATED WITH THE SUPPLIER PRODUCT MUST BE ADHERED TO.

1 SEAT DETAIL
TYPICAL LAYOUT PLAN 1:20

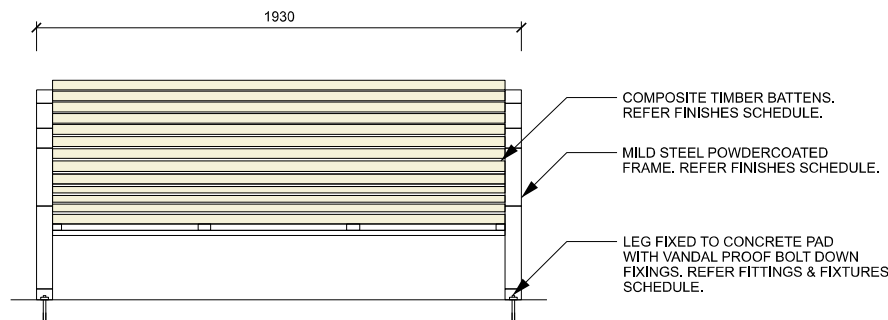

2 SEAT DETAIL
TYPICAL FRONT ELEVATION 1:20

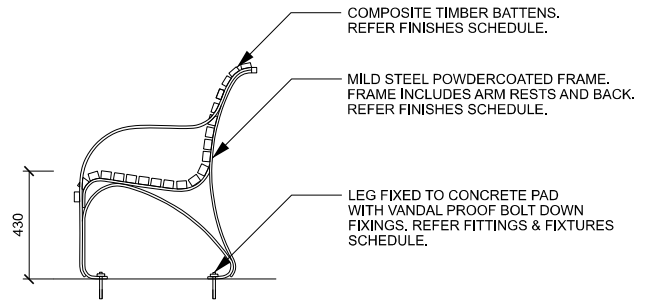

3 SEAT DETAIL
TYPICAL SIDE ELEVATION 1:20

REV.	DESCRIPTION	DATE	DRN	CHKD
1	PRELIMINARY	03.08.23	E.B.	R.D.
2	PRELIMINARY	22.11.23	S.M.	R.D.
3	COUNCIL ISSUE	12.07.24	M.M.	R.D.

NOTES

- ALL MEASUREMENTS ARE IN MILLIMETRES UNLESS OTHERWISE STATED.
- REFER WYNDHAM CITY COUNCIL WEBSITE TO ENSURE DRAWINGS ARE THE LATEST REVISION.
- DRAWINGS ARE CONCEPT ONLY AND NOT SPECIFIC TO ANY SITE OR SITE CONDITIONS.
- DRAWINGS CONTAIN TYPICAL ENGINEERING DETAIL FOR INFORMATION ONLY AND WILL REQUIRE PROJECT AND SITE SPECIFIC STRUCTURAL ENGINEERING AND OR SHOP DRAWINGS.
- DRAWINGS WILL BE SUBJECT TO CHANGE THROUGHOUT DESIGN AND CONSTRUCTION PROCESS.
- OVERALL LAYOUT, SIZE AND THEME WILL NOT CHANGE.
- THE DESIGN ASSUMES THAT THE DESIGN WILL BE DEVELOPED AND CONSTRUCTED BY A SUITABLY QUALIFIED CONTRACTOR WITH MINIMUM 10 YEARS RELEVANT INDUSTRY EXPERIENCE.



STANDARD DETAIL - LANDSCAPE
**OPEN SPACE FURNITURE
SEAT
SHEET 2 OF 2**

STATUS	COUNCIL ISSUE	NOT FOR CONSTRUCTION
SCALE		DATE
AS SHOWN		03.08.2023
DWG No.		REV
OS 105B		3

NOTE: MANHATTAN STYLE BENCH IS FOR PARKS.

SUPPLIER: COMMERCIAL SYSTEMS OR APPROVED SIMILAR.
PRODUCT CODE: TM4511 MANHATTAN BENCH

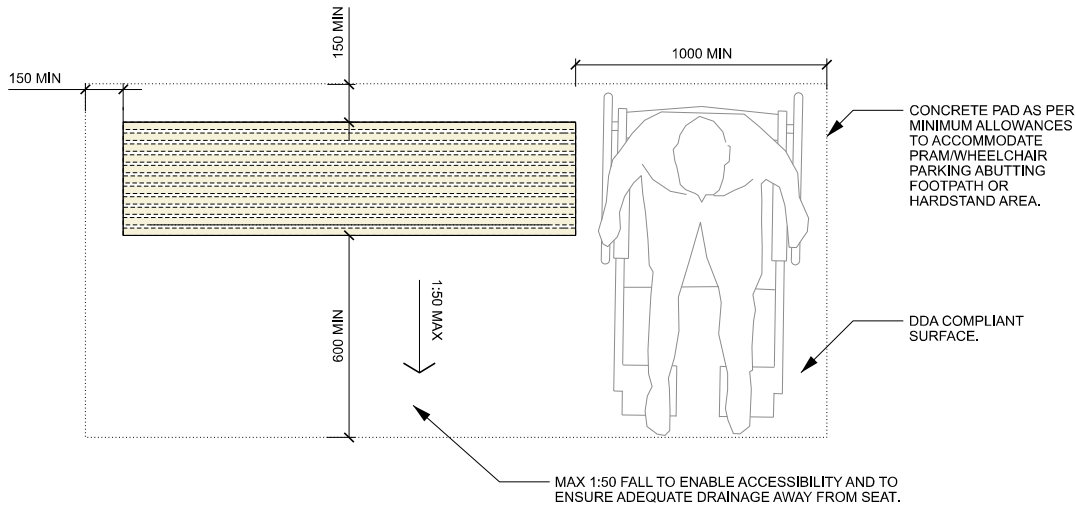

Fittings & Fixtures Schedule					
Reference Images	Item	Model/Details	Material	Notes	Alternative
To comply with Australian Standards (AS1428.1)					
	Dolt down fixing		Stainless Steel	Refer to finishes schedule for fixing finish. All fixings to be same treatment.	N/A

Finishes Schedule			
Item	Material	Finish	Alternative Finish
Frame	Mild Steel	Preferred Finish: Monument (black) Powder coated finish.	Alternative Finish: 304 Stainless Steel or alternative powdercoat colour. All alternative finishes and materials are subject to council review and approval.
Battens	Enviroslat Recycled Battens	Preferred Finish: Walnut 40mm x 60mm.	N/A
Fixings	Stainless Steel	All fixings to be stainless steel or galvanised anti-vandal fixings. All exposed fixings to be capped.	N/A
Ground Surface	Hardstand Area to match minimum dimensions shown on plans.	Minimum plain grey concrete with medium broom finish or to match other hardstand surfaces within scope of project works.	

NOTE: ALL CHANGES TO COUNCIL'S PREFERRED FINISHES TO BE SHOWN IN RED FOR COUNCIL APPROVAL.

DETAILS PROVIDED ARE CONSISTENT WITH THE SUPPLIER'S PRODUCT. ALTERNATIVE SUPPLIERS/MANUFACTURERS MAY BE PROPOSED. GENERAL DESIGN THEMES AND MEASUREMENTS SHOULD BE FOLLOWED WHILE ENSURING NO COPYRIGHT LAWS ARE BREACHED. ALL OTHER REQUIREMENTS, MATERIALS, FINISHES AND FIXING METHODS LISTED IN THIS DETAIL NOT ASSOCIATED WITH THE SUPPLIER PRODUCT MUST BE ADHERED TO.

1 BENCH DETAIL
TYPICAL LAYOUT PLAN 1:20

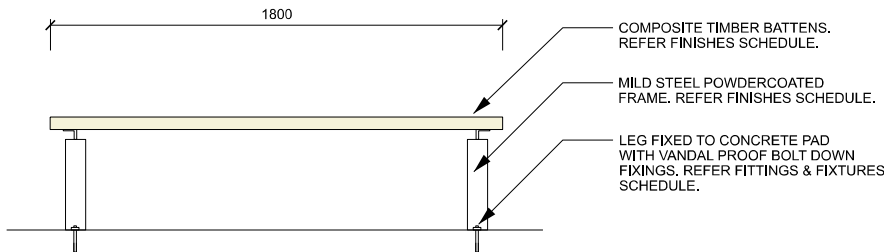

2 BENCH DETAIL
TYPICAL FRONT ELEVATION 1:20

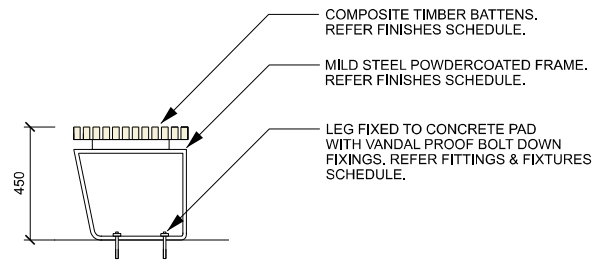

3 BENCH DETAIL
TYPICAL SIDE ELEVATION 1:20

REV.	DESCRIPTION	DATE	DRN	CHKD
1	PRELIMINARY	03.08.23	E.B.	R.D.
2	PRELIMINARY	22.11.23	S.M.	R.D.
3	COUNCIL ISSUE	12.07.24	M.M.	R.D.

NOTES

- ALL MEASUREMENTS ARE IN MILLIMETRES UNLESS OTHERWISE STATED.
- REFER WYNDHAM CITY COUNCIL WEBSITE TO ENSURE DRAWINGS ARE THE LATEST REVISION.
- DRAWINGS ARE CONCEPT ONLY AND NOT SPECIFIC TO ANY SITE OR SITE CONDITIONS.
- DRAWINGS CONTAIN TYPICAL ENGINEERING DETAIL FOR INFORMATION ONLY AND WILL REQUIRE PROJECT AND SITE SPECIFIC STRUCTURAL ENGINEERING AND OR SHOP DRAWINGS.
- DRAWINGS WILL BE SUBJECT TO CHANGE THROUGHOUT DESIGN AND CONSTRUCTION PROCESS.
- OVERALL LAYOUT, SIZE AND THEME WILL NOT CHANGE.
- THE DESIGN ASSUMES THAT THE DESIGN WILL BE DEVELOPED AND CONSTRUCTED BY A SUITABLY QUALIFIED CONTRACTOR WITH MINIMUM 10 YEARS RELEVANT INDUSTRY EXPERIENCE.



STANDARD DETAIL - LANDSCAPE

OPEN SPACE FURNITURE

BENCH SEAT

SHEET 1 OF 2

STATUS	COUNCIL ISSUE	NOT FOR CONSTRUCTION
SCALE		DATE
AS SHOWN		03.08.2023
DWG No.		REV
OS 106A		3

NOTE: ALBERT PARK BENCH SEAT IS FOR SHARED PATH TRAILS.

SUPPLIER: COMMERCIAL SYSTEMS OR APPROVED SIMILAR.
PRODUCT CODE: TM4135 CLASSIC BENCH

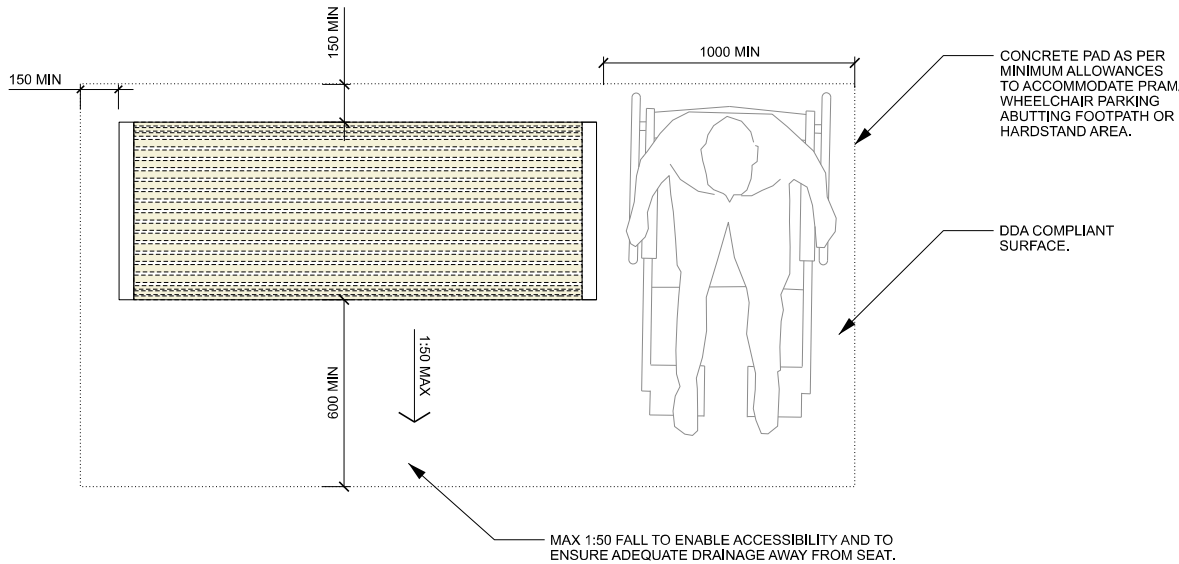

Fittings & Fixtures Schedule					
Reference images	Item	Model/Details	Material	Notes	Alternative
To comply with Australian Standards (AS1428.1)					
	Bolt down fixing		Stainless Steel	Refer to finishes schedule for fixing finish. All fixings to be same treatment.	N/A
	Armrests		Mild steel	Armrest finish to match frame.	N/A

Finishes Schedule			
Item	Material	Finish	Alternative Finish
Frame	Mild steel	Preferred Finish: Monument (black) Powder coated finish.	Alternative Finish: 304 Stainless Steel or alternative powdercoat colour. All alternative finishes and materials are subject to council review and approval.
Battens	Enviroslat Recycled Battens	Preferred Finish: Walnut 40mm x 60mm.	N/A
Fixings	Stainless Steel	All fixings to be stainless steel or galvanised anti-vandal fixings. All exposed fixings to be capped.	N/A
Ground Surface	Hardstand Area to match minimum dimensions shown on plans.	Minimum plain grey concrete with medium broom finish or to match other hardstand surfaces within scope of project works.	

NOTE: ALL CHANGES TO COUNCIL'S PREFERRED FINISHES TO BE SHOWN IN RED FOR COUNCIL APPROVAL.

DETAILS PROVIDED ARE CONSISTENT WITH THE SUPPLIER'S PRODUCT. ALTERNATIVE SUPPLIERS/MANUFACTURERS MAY BE PROPOSED. GENERAL DESIGN THEMES AND MEASUREMENTS SHOULD BE FOLLOWED WHILE ENSURING NO COPYRIGHT LAWS ARE BREACHED. ALL OTHER REQUIREMENTS, MATERIALS, FINISHES AND FIXING METHODS LISTED IN THIS DETAIL NOT ASSOCIATED WITH THE SUPPLIER PRODUCT MUST BE ADHERED TO.

1 BENCH DETAIL
TYPICAL LAYOUT PLAN 1:20

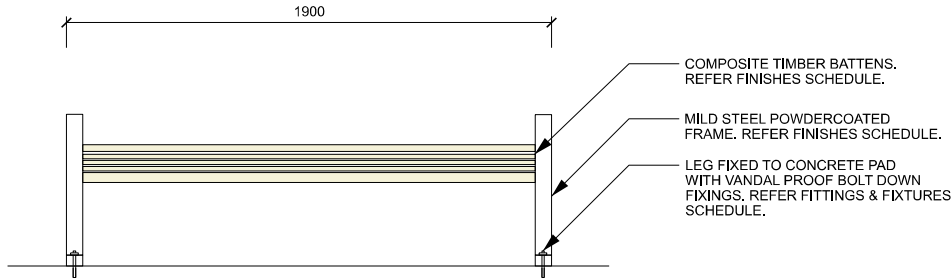

2 BENCH DETAIL
TYPICAL FRONT ELEVATION 1:20

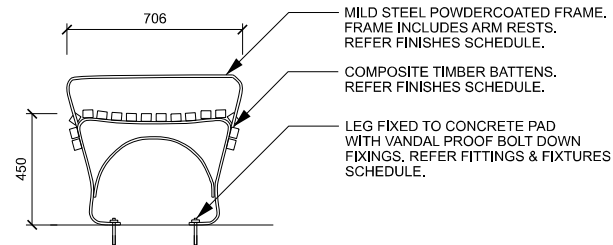

3 BENCH DETAIL
TYPICAL SIDE ELEVATION 1:20

REV.	DESCRIPTION	DATE	DRN	CHKD	NOTES
1	PRELIMINARY	03.08.23	E.B.	R.D.	- ALL MEASUREMENTS ARE IN MILLIMETRES UNLESS OTHERWISE STATED. - REFER WYNDHAM CITY COUNCIL WEBSITE TO ENSURE DRAWINGS ARE THE LATEST REVISION.
2	PRELIMINARY	22.11.23	S.M.	R.D.	- DRAWINGS ARE CONCEPT ONLY AND NOT SPECIFIC TO ANY SITE OR SITE CONDITIONS. - DRAWINGS CONTAIN TYPICAL ENGINEERING DETAIL FOR INFORMATION ONLY AND WILL REQUIRE PROJECT AND SITE SPECIFIC STRUCTURAL ENGINEERING AND OR SHOP DRAWINGS.
3	COUNCIL ISSUE	12.07.24	M.M.	R.D.	- DRAWINGS WILL BE SUBJECT TO CHANGE THROUGHOUT DESIGN AND CONSTRUCTION PROCESS. - OVERALL LAYOUT, SIZE AND THEME WILL NOT CHANGE. - THE DESIGN ASSUMES THAT THE DESIGN WILL BE DEVELOPED AND CONSTRUCTED BY A SUITABLY QUALIFIED CONTRACTOR WITH MINIMUM 10 YEARS RELEVANT INDUSTRY EXPERIENCE.

NOTES

- ALL MEASUREMENTS ARE IN MILLIMETRES UNLESS OTHERWISE STATED.
- REFER WYNDHAM CITY COUNCIL WEBSITE TO ENSURE DRAWINGS ARE THE LATEST REVISION.
- DRAWINGS ARE CONCEPT ONLY AND NOT SPECIFIC TO ANY SITE OR SITE CONDITIONS.
- DRAWINGS CONTAIN TYPICAL ENGINEERING DETAIL FOR INFORMATION ONLY AND WILL REQUIRE PROJECT AND SITE SPECIFIC STRUCTURAL ENGINEERING AND OR SHOP DRAWINGS.
- DRAWINGS WILL BE SUBJECT TO CHANGE THROUGHOUT DESIGN AND CONSTRUCTION PROCESS.
- OVERALL LAYOUT, SIZE AND THEME WILL NOT CHANGE.
- THE DESIGN ASSUMES THAT THE DESIGN WILL BE DEVELOPED AND CONSTRUCTED BY A SUITABLY QUALIFIED CONTRACTOR WITH MINIMUM 10 YEARS RELEVANT INDUSTRY EXPERIENCE.



STANDARD DETAIL - LANDSCAPE

OPEN SPACE FURNITURE

BENCH SEAT

SHEET 2 OF 2

STATUS	COUNCIL ISSUE	NOT FOR CONSTRUCTION
SCALE		DATE
AS SHOWN		03.08.2023
DWG No.		REV
OS 106B		3

SUPPLIER: COMMERCIAL SYSTEMS OR APPROVED SIMILAR.
PRODUCT CODE: TM4515 MANHATTAN BENCH

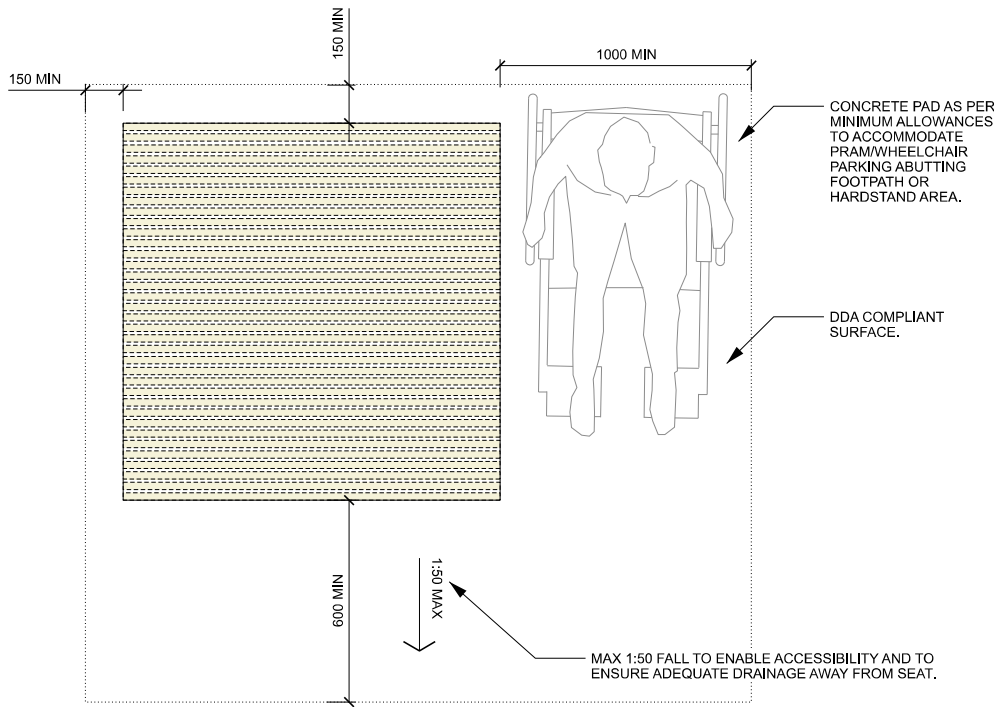

1 PLATFORM BENCH DETAIL
TYPICAL LAYOUT PLAN

1:20

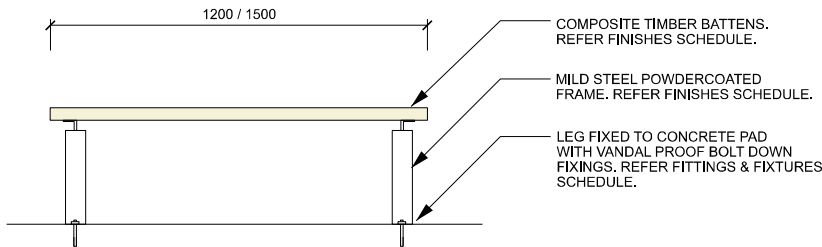

2 PLATFORM BENCH DETAIL
TYPICAL FRONT ELEVATION

1:20

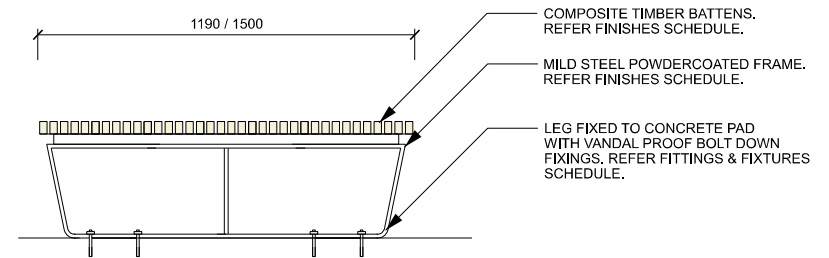

3 PLATFORM BENCH DETAIL
TYPICAL SIDE ELEVATION

1:20

Fittings & Fixtures Schedule					
Reference images	Item	Model/Details	Material	Notes	Alternative
To comply with Australian Standards (AS1428.1)					
	Bolt down fixing		Stainless Steel	Refer to finishes schedule for fixing finish. All fixings to be same treatment.	N/A

Finishes Schedule			
Item	Material	Finish	Alternative Finish
Frame	Mild Steel	Preferred Finish: Monument (black) Powder coated finish.	Alternative Finish: 304 Stainless Steel or alternative powdercoat colour. All alternative finishes and materials are subject to council review and approval.
Battens	Enviroslat Recycled Battens	Preferred Finish: Walnut 40mm x 60mm.	N/A
Fixings	Stainless Steel	All fixings to be stainless steel or galvanised anti-vandal fixings. All exposed fixings to be capped.	N/A
Ground Surface	Hardstand Area to match minimum dimensions shown on plans.	Minimum plain grey concrete with medium broom finish or to match other hardstand surfaces within scope of project works.	

NOTE: ALL CHANGES TO COUNCIL'S PREFERRED FINISHES TO BE SHOWN IN RED FOR COUNCIL APPROVAL.

DETAILS PROVIDED ARE CONSISTENT WITH THE SUPPLIER'S PRODUCT. ALTERNATIVE SUPPLIERS/MANUFACTURERS MAY BE PROPOSED. GENERAL DESIGN THEMES AND MEASUREMENTS SHOULD BE FOLLOWED WHILE ENSURING NO COPYRIGHT LAWS ARE BREACHED. ALL OTHER REQUIREMENTS, MATERIALS, FINISHES AND FIXING METHODS LISTED IN THIS DETAIL NOT ASSOCIATED WITH THE SUPPLIER PRODUCT MUST BE ADHERED TO.

REV.	DESCRIPTION	DATE	DRN	CHKD
1	PRELIMINARY	22.11.23	S.W.	R.D.
2	PRELIMINARY	14.12.23	M.M.	R.D.
3	COUNCIL ISSUE	12.07.24	M.M.	R.D.

NOTES

- ALL MEASUREMENTS ARE IN MILLIMETRES UNLESS OTHERWISE STATED.
- REFER WYNDHAM CITY COUNCIL WEBSITE TO ENSURE DRAWINGS ARE THE LATEST REVISION.
- DRAWINGS ARE CONCEPT ONLY AND NOT SPECIFIC TO ANY SITE OR SITE CONDITIONS.
- DRAWINGS CONTAIN TYPICAL ENGINEERING DETAIL FOR INFORMATION ONLY AND WILL REQUIRE PROJECT AND SITE SPECIFIC STRUCTURAL ENGINEERING AND OR SHOP DRAWINGS.
- DRAWINGS WILL BE SUBJECT TO CHANGE THROUGHOUT DESIGN AND CONSTRUCTION PROCESS.
- OVERALL LAYOUT, SIZE AND THEME WILL NOT CHANGE.
- THE DESIGN ASSUMES THAT THE DESIGN WILL BE DEVELOPED AND CONSTRUCTED BY A SUITABLY QUALIFIED CONTRACTOR WITH MINIMUM 10 YEARS RELEVANT INDUSTRY EXPERIENCE.



STANDARD DETAIL - LANDSCAPE
OPEN SPACE FURNITURE
PLATFORM BENCH SEAT
SHEET 1 OF 1

STATUS	COUNCIL ISSUE	NOT FOR CONSTRUCTION
SCALE		DATE
AS SHOWN		22.11.2023
DWG No.		REV
OS 107		3

A3

SUPPLIER: COMMERCIAL SYSTEMS OR APPROVED SIMILAR.
 PRODUCT CODE: TM4750 WALL MOUNTED SEAT WITH ARMS

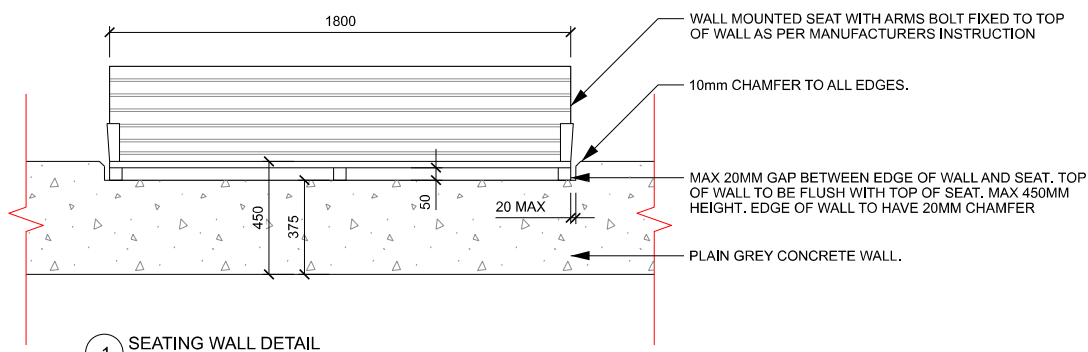

1 SEATING WALL DETAIL TYPICAL ELEVATION 1:20

Fittings & Fixtures Schedule					
Reference images	Item	Model/Details	Material	Notes	Alternative
To comply with Australian Standards (AS1428.1)					
	Bolt down fixing		Stainless Steel	Refer to finishes schedule for fixing finish. All fixings to be same treatment.	N/A

Finishes Schedule			
Item	Material	Finish	Alternative Finish
Frame	Mild Steel	Preferred Finish: Monument (black) Powder coated finish.	Alternative Finish: 304 Stainless Steel or alternative powdercoat colour. All alternative finishes and materials are subject to council review and approval.
Battens	Enviroslat Recycled Battens	Preferred Finish: Walnut 40mm x 60mm.	N/A
Fixings	Stainless Steel	All fixings to be stainless steel or galvanised anti-vandal fixings. All exposed fixings to be capped.	N/A
Seating Wall	Plain Grey Concrete.	Class 2 formwork. Finish: Medium honed finish. Apply suitable invisible anti graffiti coating.	Alternative Finish: alternative concrete colour or aggregate. All alternative finishes and materials are subject to council review and approval.

NOTE: ALL CHANGES TO COUNCIL'S PREFERRED FINISHES TO BE SHOWN IN RED FOR COUNCIL APPROVAL.

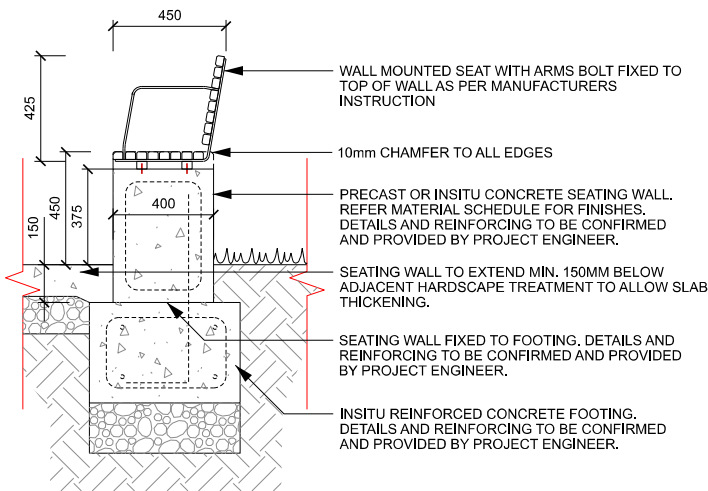

2 SEATING WALL DETAIL HARDSCAPE INTERFACE SECTION 1:20

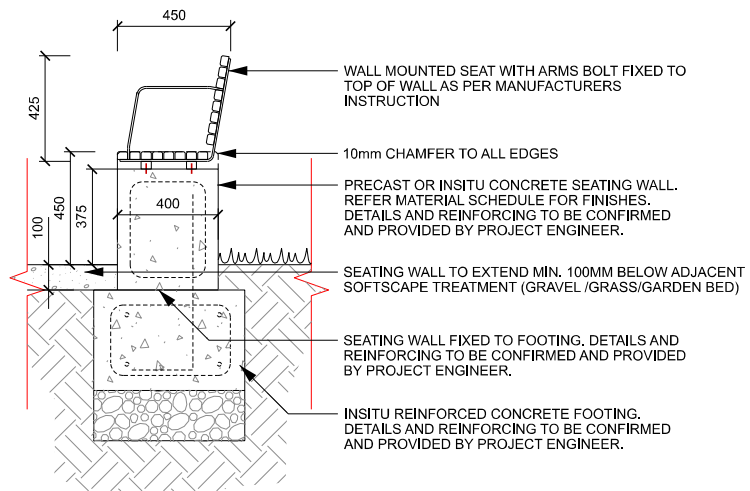

3 SEATING WALL DETAIL SOFTSCAPE INTERFACE SECTION 1:20

REV.	DESCRIPTION	DATE	DRN	CHKD
1	PRELIMINARY	01.11.23	S.W.	R.D.
2	PRELIMINARY	14.12.23	M.M.	R.D.
3	COUNCIL ISSUE	12.07.24	M.M.	R.D.

NOTES

- ALL MEASUREMENTS ARE IN MILLIMETRES UNLESS OTHERWISE STATED.
- REFER WYNDHAM CITY COUNCIL WEBSITE TO ENSURE DRAWINGS ARE THE LATEST REVISION.
- DRAWINGS ARE CONCEPT ONLY AND NOT SPECIFIC TO ANY SITE OR SITE CONDITIONS.
- DRAWINGS CONTAIN TYPICAL ENGINEERING DETAIL FOR INFORMATION ONLY AND WILL REQUIRE PROJECT AND SITE SPECIFIC STRUCTURAL ENGINEERING AND OR SHOP DRAWINGS.
- DRAWINGS WILL BE SUBJECT TO CHANGE THROUGHOUT DESIGN AND CONSTRUCTION PROCESS.
- OVERALL LAYOUT, SIZE AND THEME WILL NOT CHANGE.
- THE DESIGN ASSUMES THAT THE DESIGN WILL BE DEVELOPED AND CONSTRUCTED BY A SUITABLY QUALIFIED CONTRACTOR WITH MINIMUM 10 YEARS RELEVANT INDUSTRY EXPERIENCE.



STANDARD DETAIL - LANDSCAPE

OPEN SPACE FURNITURE

SEATING WALL

SHEET 1 OF 2

STATUS	COUNCIL ISSUE	NOT FOR CONSTRUCTION
SCALE		DATE
AS SHOWN		22.11.2023
DWG No.		REV
OS 108A		3

Finishes Schedule			
Item	Material	Finish	Alternative Finish
Seating Wall	Plain Grey Concrete.	Class 2 formwork. Finish: Medium honed finish. Apply suitable invisible anti graffiti coating.	Alternative Finish: alternative concrete colour or aggregate. All alternative finishes and materials are subject to council review and approval.

NOTE: ALL CHANGES TO COUNCIL'S PREFERRED FINISHES TO BE SHOWN IN RED FOR COUNCIL APPROVAL.

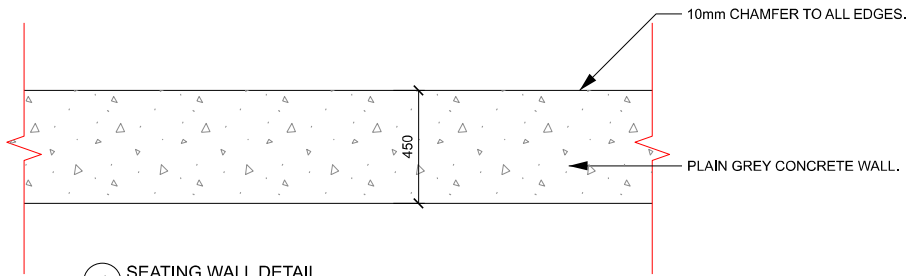

1 SEATING WALL DETAIL
TYPICAL ELEVATION 1:20

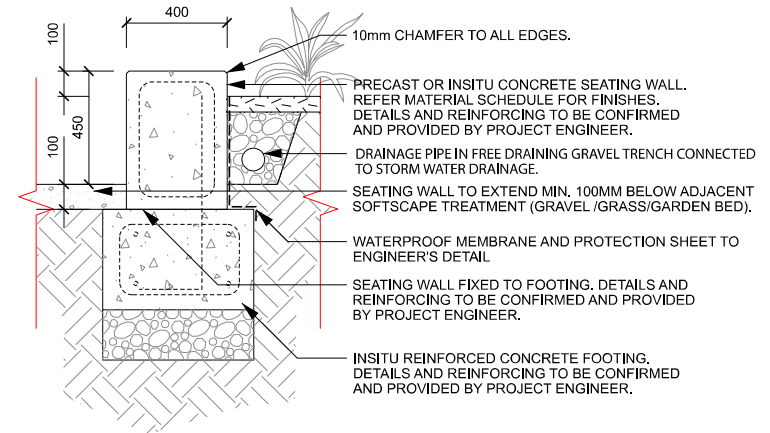

2 SEATING WALL DETAIL
SOFTSCAPE RETAINER SECTION 1:20

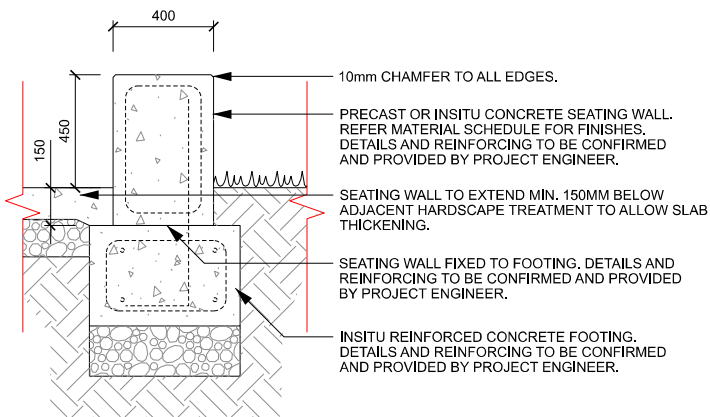

3 SEATING WALL DETAIL
HARDSCAPE INTERFACE SECTION 1:20

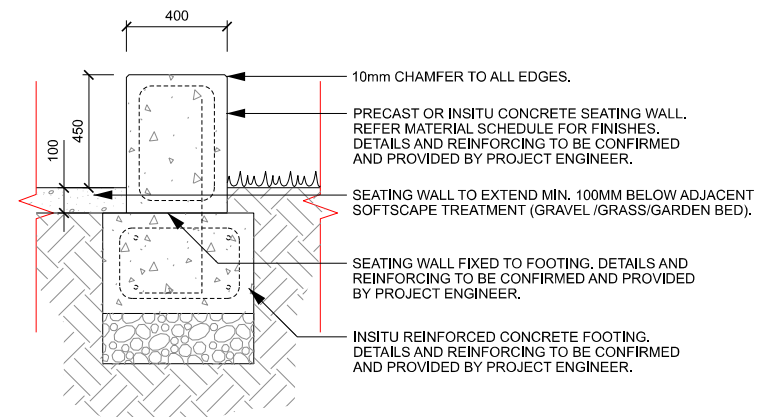

4 SEATING WALL DETAIL
SOFTSCAPE INTERFACE SECTION 1:20

REV.	DESCRIPTION	DATE	DRN	CHKD
1	PRELIMINARY	01.11.23	S.M.	R.D.
2	PRELIMINARY	14.12.23	M.M.	R.D.
3	COUNCIL ISSUE	12.07.24	M.M.	R.D.

NOTES

- ALL MEASUREMENTS ARE IN MILLIMETRES UNLESS OTHERWISE STATED.
- REFER WYNDHAM CITY COUNCIL WEBSITE TO ENSURE DRAWINGS ARE THE LATEST REVISION.
- DRAWINGS ARE CONCEPT ONLY AND NOT SPECIFIC TO ANY SITE OR SITE CONDITIONS.
- DRAWINGS CONTAIN TYPICAL ENGINEERING DETAIL FOR INFORMATION ONLY AND WILL REQUIRE PROJECT AND SITE SPECIFIC STRUCTURAL ENGINEERING AND OR SHOP DRAWINGS.
- DRAWINGS WILL BE SUBJECT TO CHANGE THROUGHOUT DESIGN AND CONSTRUCTION PROCESS.
- OVERALL LAYOUT, SIZE AND THEME WILL NOT CHANGE.
- THE DESIGN ASSUMES THAT THE DESIGN WILL BE DEVELOPED AND CONSTRUCTED BY A SUITABLY QUALIFIED CONTRACTOR WITH MINIMUM 10 YEARS RELEVANT INDUSTRY EXPERIENCE.



STANDARD DETAIL - LANDSCAPE

OPEN SPACE FURNITURE
SEATING WALL
SHEET 2 OF 2

STATUS COUNCIL ISSUE NOT FOR CONSTRUCTION

SCALE	DATE
AS SHOWN	22.11.2023
DWG No.	REV
OS 108B	3

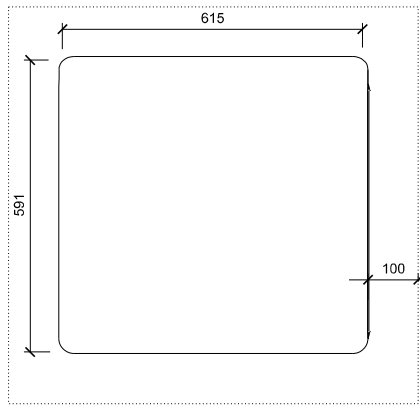

MINIMUM 100mm CONCRETE BETWEEN EDGE AND BOLT DOWN FIXING POINTS.

PREFERRED ALIGNMENT OUTSIDE OF PATHS OF TRAVEL AND WITHIN GARDEN BED WHERE SUITABLE

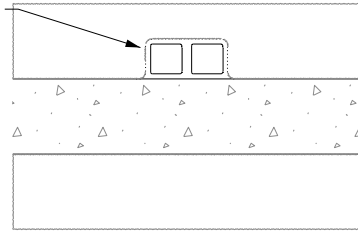

1 BIN ENCLOSURE TYPICAL PLAN 1:10

4 BIN ENCLOSURE TYPICAL SET OUT PLAN 1:100

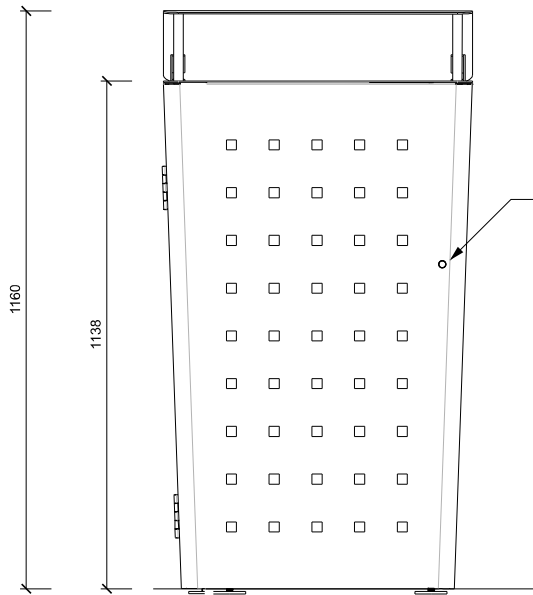

DOOR WITH 8mm TRIANGULAR LOCK, ACCESSIBLE FROM PATH FOR MAINTENANCE.

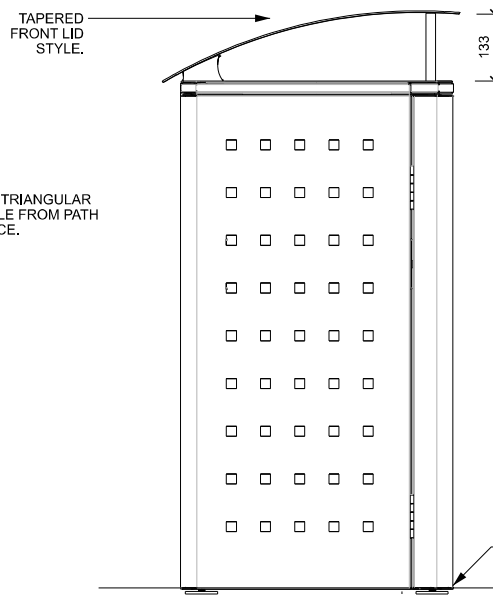

BOLT DOWN FIXING TO CONCRETE AS PER MANUFACTURER'S SPECIFICATION. PAVING DETAILS AND REINFORCING TO BE CONFIRMED AND PROVIDED BY PROJECT ENGINEER.

2 BIN ENCLOSURE TYPICAL FRONT ELEVATION 1:10

3 BIN ENCLOSURE TYPICAL SIDE ELEVATION 1:10

SUPPLIER: COMMERCIAL SYSTEMS OR APPROVED SIMILAR. PRODUCT CODE: LR6157 WYNDHAM BIN ENCLOSURE

NOTE:
- BIN ENCLOSURE TO BE FRONT OPENING ONLY.
- 120 LITRE BIN TO BE INSTALLED INTERNALLY OF BIN ENCLOSURE. BIN TO INCLUDE WHEELS AND HAVE LIDS REMOVED.

Fittings & Fixtures Schedule					
Reference images	Item	Model/Details	Material	Notes	Alternative
To comply with Australian Standards (AS1428.1)					
	Bolt down fixing		Stainless Steel	Refer to finishes schedule for fixing finish. All fixings to be same treatment.	N/A

Finishes Schedule			
Item	Material	Finish	Alternative Finish
Canopy and Lid	Stainless Steel	Stainless Steel	N/A
Body	Mild Steel	Preferred Finish: Monument (black) Powder coated finish.	N/A
Fixings	Stainless Steel	All fixings to be stainless steel, galvanised or powder coated anti-vandal fixings. All exposed fixings to be capped.	N/A
Ground Surface	Hardstand Area to match minimum dimensions shown on plans.	Minimum plain grey concrete with medium broom finish or to match other hardstand surfaces within scope of project works.	

NOTE: ALL CHANGES TO COUNCIL'S PREFERRED FINISHES TO BE SHOWN IN RED FOR COUNCIL APPROVAL.

REV.	DESCRIPTION	DATE	DRN	CHKD
1	PRELIMINARY	01.09.23	E.B.	R.D.
2	PRELIMINARY	01.11.23	S.M.	R.D.
3	COUNCIL ISSUE	12.07.24	M.M.	R.D.

NOTES

- ALL MEASUREMENTS ARE IN MILLIMETRES UNLESS OTHERWISE STATED.
- REFER WYNDHAM CITY COUNCIL WEBSITE TO ENSURE DRAWINGS ARE THE LATEST REVISION.
- DRAWINGS ARE CONCEPT ONLY AND NOT SPECIFIC TO ANY SITE OR SITE CONDITIONS.
- DRAWINGS CONTAIN TYPICAL ENGINEERING DETAIL FOR INFORMATION ONLY AND WILL REQUIRE PROJECT AND SITE SPECIFIC STRUCTURAL ENGINEERING AND OR SHOP DRAWINGS.
- DRAWINGS WILL BE SUBJECT TO CHANGE THROUGHOUT DESIGN AND CONSTRUCTION PROCESS.
- OVERALL LAYOUT, SIZE AND THEME WILL NOT CHANGE.
- THE DESIGN ASSUMES THAT THE DESIGN WILL BE DEVELOPED AND CONSTRUCTED BY A SUITABLY QUALIFIED CONTRACTOR WITH MINIMUM 10 YEARS RELEVANT INDUSTRY EXPERIENCE.



STANDARD DETAIL - LANDSCAPE

OPEN SPACE FURNITURE
BIN ENCLOSURE
SHEET 1 OF 1

STATUS COUNCIL ISSUE NOT FOR CONSTRUCTION

SCALE DATE

AS SHOWN 01.09.2023

DWG No. REV

OS 109 3 A3

SUPPLIER: GRILEX OR APPROVED SIMILAR.
 PRODUCT CODE: FDB-DC-STD-002
 FRONTIER BBQ WITH REAR ACCESS DOOR.

NOTE: BBQ TO BE POSITIONED AGAINST THE
 EDGE OF THE ROOFLINE WHEN INSTALLED
 UNDER SHELTER TO ENSURE ADEQUATE
 VENTILATION.

SINGLE HOTPLATE OPTION ALSO
 ACCEPTABLE (SUBJECT TO COUNCIL
 APPROVAL PRIOR BASED ON SITE
 REQUIREMENTS).
 PRODUCT CODE: FSB-SC-STD-002

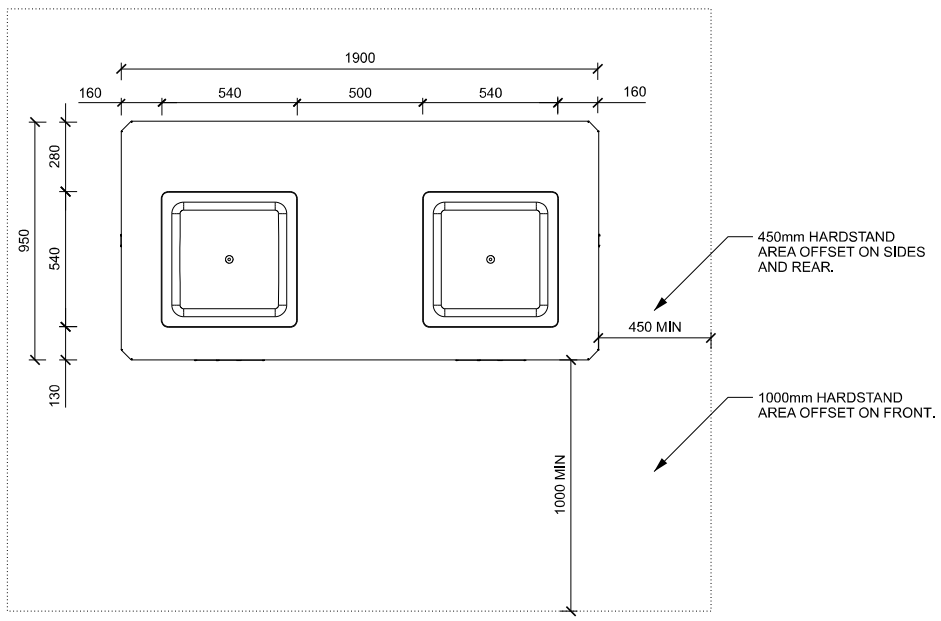

Finishes Schedule			
Item	Material	Finish	Alternative Finish
BBQ	stainless steel	All finishes to be stainless steel. All exposed fixings to be capped.	N/A

NOTE: ALL CHANGES TO COUNCIL'S PREFERRED FINISHES TO BE SHOWN IN RED FOR COUNCIL APPROVAL.

1 ACCESSIBLE BBQ, DUAL HOTPLATE
 TYPICAL PLAN 1:20

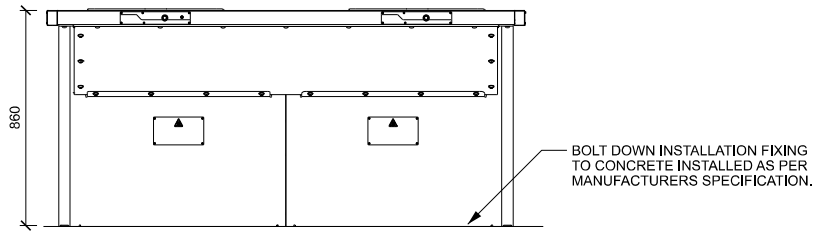

2 ACCESSIBLE BBQ, DUAL HOTPLATE
 TYPICAL FRONT ELEVATION 1:20

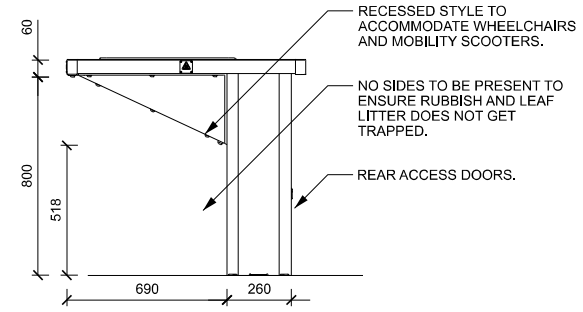

3 ACCESSIBLE BBQ, DUAL HOTPLATE
 TYPICAL SIDE ELEVATION 1:20

REV.	DESCRIPTION	DATE	DRN	CHKD
1	PRELIMINARY	08.09.23	E.B.	R.D.
2	PRELIMINARY	22.11.23	S.M.	R.D.
3	COUNCIL ISSUE	12.07.24	M.M.	R.D.

NOTES

- ALL MEASUREMENTS ARE IN MILLIMETRES UNLESS OTHERWISE STATED.
- REFER WYNDHAM CITY COUNCIL WEBSITE TO ENSURE DRAWINGS ARE THE LATEST REVISION.
- DRAWINGS ARE CONCEPT ONLY AND NOT SPECIFIC TO ANY SITE OR SITE CONDITIONS.
- DRAWINGS CONTAIN TYPICAL ENGINEERING DETAIL FOR INFORMATION ONLY AND WILL REQUIRE PROJECT AND SITE SPECIFIC STRUCTURAL ENGINEERING AND OR SHOP DRAWINGS.
- DRAWINGS WILL BE SUBJECT TO CHANGE THROUGHOUT DESIGN AND CONSTRUCTION PROCESS.
- OVERALL LAYOUT, SIZE AND THEME WILL NOT CHANGE.
- THE DESIGN ASSUMES THAT THE DESIGN WILL BE DEVELOPED AND CONSTRUCTED BY A SUITABLY QUALIFIED CONTRACTOR WITH MINIMUM 10 YEARS RELEVANT INDUSTRY EXPERIENCE.



STANDARD DETAIL - LANDSCAPE

OPEN SPACE FURNITURE

ACCESSIBLE BBQ, DUAL HOTPLATE

SHEET 1 OF 1

STATUS	COUNCIL ISSUE	NOT FOR CONSTRUCTION
SCALE		DATE
AS SHOWN		08.09.2023
DWG No.		REV
OS 110		3

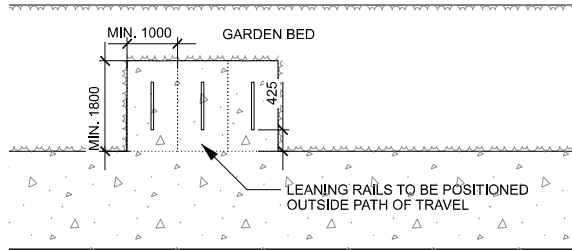

SUPPLIER: COMMERCIAL SYSTEMS OR APPROVED SIMILAR.
 PRODUCT CODE:
 BR7011 BIKE LEANING RAIL (ANGULAR)
 BR7008 BIKE LEANING RAIL (CURVED).

NOTE:
 - BOLT DOWN FIXING PREFERRED.
 EXTENDED LEG FOOTING MAY BE ACCEPTED ON CASE BY CASE BASIS.

1 LEANING RAIL
 TYPICAL SETOUT PLAN 1:100

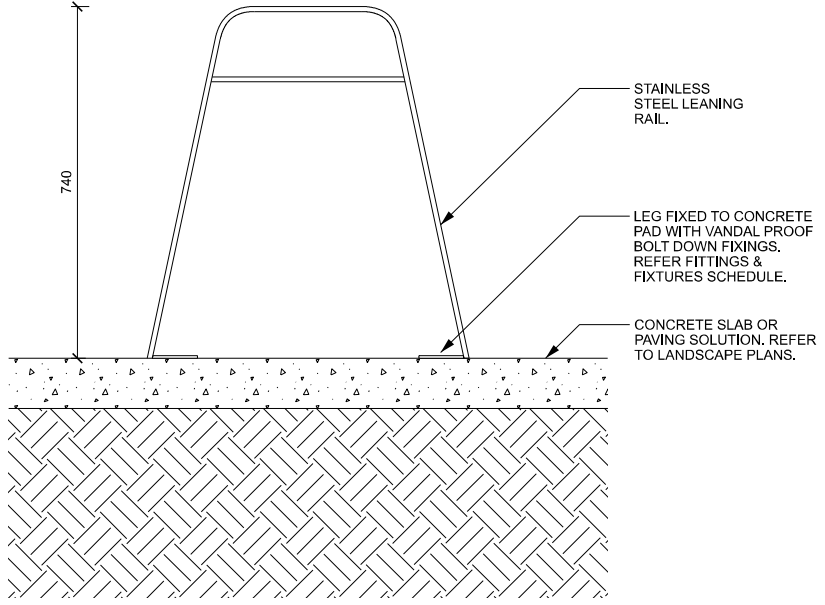

2 ANGULAR BIKE LEANING RAIL
 TYPICAL SECTION 1:10

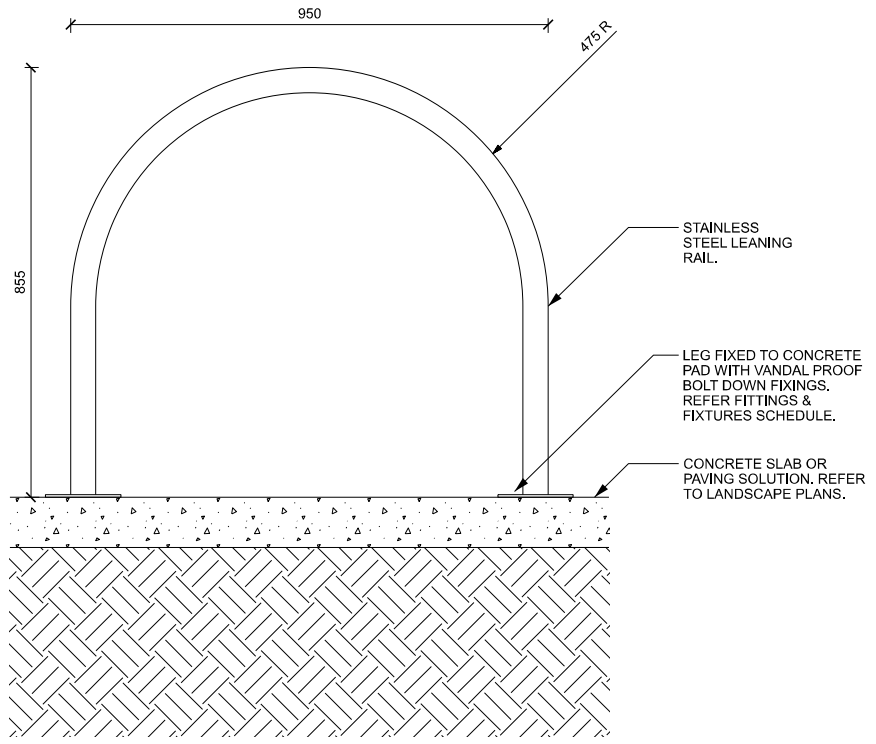

3 CURVED BIKE LEANING RAIL
 TYPICAL SECTION 1:10

REV.	DESCRIPTION	DATE	DRN	CHKD
1	PRELIMINARY	08.09.23	E.B.	R.D.
2	PRELIMINARY	01.11.23	S.M.	R.D.
3	PRELIMINARY	14.12.23	M.M.	R.D.
4	COUNCIL ISSUE	12.07.24	M.M.	R.D.

NOTES

- ALL MEASUREMENTS ARE IN MILLIMETRES UNLESS OTHERWISE STATED.
- REFER WYNDHAM CITY COUNCIL WEBSITE TO ENSURE DRAWINGS ARE THE LATEST REVISION.
- DRAWINGS ARE CONCEPT ONLY AND NOT SPECIFIC TO ANY SITE OR SITE CONDITIONS.
- DRAWINGS CONTAIN TYPICAL ENGINEERING DETAIL FOR INFORMATION ONLY AND WILL REQUIRE PROJECT AND SITE SPECIFIC STRUCTURAL ENGINEERING AND OR SHOP DRAWINGS.
- DRAWINGS WILL BE SUBJECT TO CHANGE THROUGHOUT DESIGN AND CONSTRUCTION PROCESS.
- OVERALL LAYOUT, SIZE AND THEME WILL NOT CHANGE.
- THE DESIGN ASSUMES THAT THE DESIGN WILL BE DEVELOPED AND CONSTRUCTED BY A SUITABLY QUALIFIED CONTRACTOR WITH MINIMUM 10 YEARS RELEVANT INDUSTRY EXPERIENCE.



STANDARD DETAIL - LANDSCAPE

OPEN SPACE FURNITURE
 BIKE LEANING RAIL
 SHEET 1 OF 1

STATUS	COUNCIL ISSUE	NOT FOR CONSTRUCTION
SCALE	AS SHOWN	DATE
DWG No.	OS 111	REV
		4

SUPPLIER: COMMERCIAL SYSTEMS OR APPROVED SIMILAR. PRODUCT CODE: LR6520 DOGGIE BAG DISPENSER

NOTE: ALTERNATIVELY, DOG BAG DISPENSER CAN BE FIXED TO OFF LEAD DOG PARK FENCING OR SIGN POST.

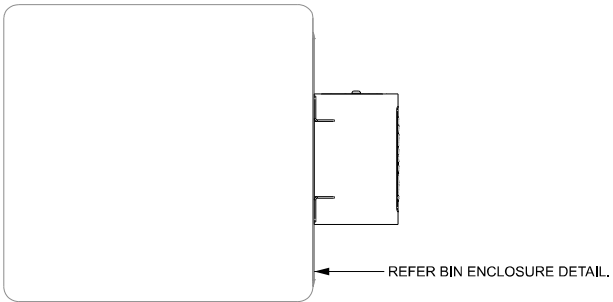

1 DOG BAG DISPENSER FIXED TO BIN ENCLOSURE
TYPICAL PLAN 1:10



4 DOG BAG DISPENSER PREFERRED TYPE
BENCHMARKING IMAGE NTS

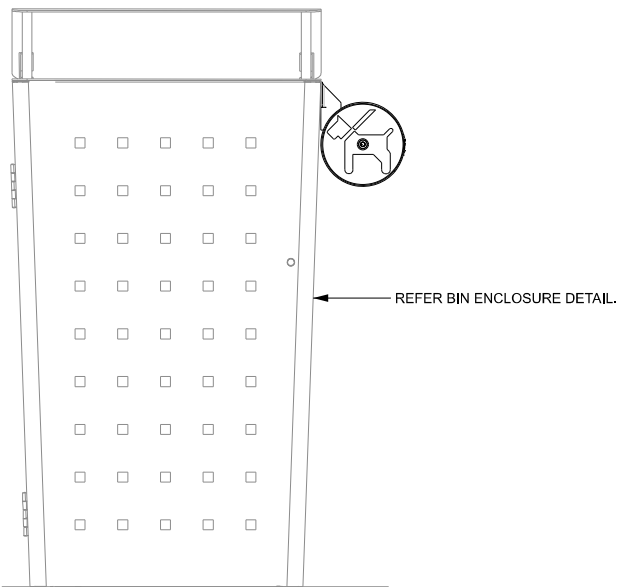

2 DOG BAG DISPENSER FIXED TO BIN ENCLOSURE
TYPICAL FRONT ELEVATION 1:20

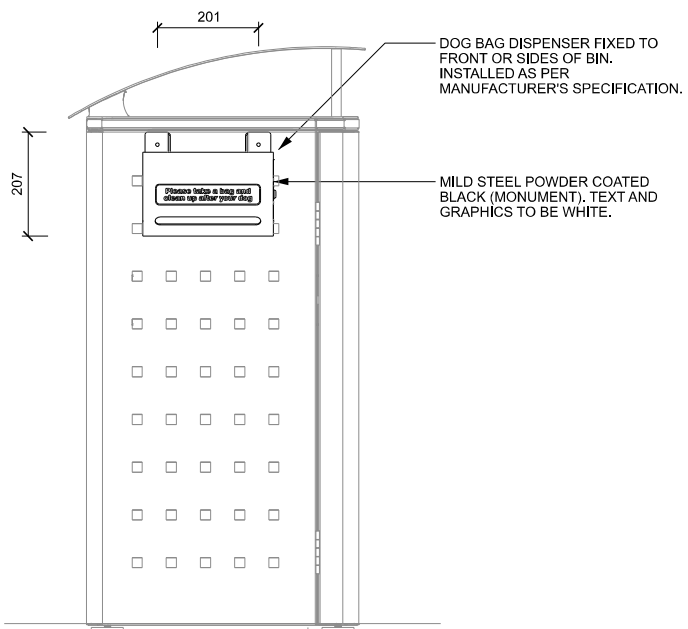

3 DOG BAG DISPENSER FIXED TO BIN ENCLOSURE
TYPICAL SIDE ELEVATION 1:20

REV.	DESCRIPTION	DATE	DRN	CHKD
1	PRELIMINARY	08.09.23	E.B.	R.D.
2	PRELIMINARY	01.11.23	S.M.	R.D.
3	PRELIMINARY	14.12.23	M.M.	R.D.
4	COUNCIL ISSUE	12.07.24	M.M.	R.D.

NOTES

- ALL MEASUREMENTS ARE IN MILLIMETRES UNLESS OTHERWISE STATED.
- REFER WYNDHAM CITY COUNCIL WEBSITE TO ENSURE DRAWINGS ARE THE LATEST REVISION.
- DRAWINGS ARE CONCEPT ONLY AND NOT SPECIFIC TO ANY SITE OR SITE CONDITIONS.
- DRAWINGS CONTAIN TYPICAL ENGINEERING DETAIL FOR INFORMATION ONLY AND WILL REQUIRE PROJECT AND SITE SPECIFIC STRUCTURAL ENGINEERING AND OR SHOP DRAWINGS.
- DRAWINGS WILL BE SUBJECT TO CHANGE THROUGHOUT DESIGN AND CONSTRUCTION PROCESS.
- OVERALL LAYOUT, SIZE AND THEME WILL NOT CHANGE.
- THE DESIGN ASSUMES THAT THE DESIGN WILL BE DEVELOPED AND CONSTRUCTED BY A SUITABLY QUALIFIED CONTRACTOR WITH MINIMUM 10 YEARS RELEVANT INDUSTRY EXPERIENCE.



STANDARD DETAIL - LANDSCAPE

OPEN SPACE FURNITURE

DOG BAG DISPENSER

SHEET 1 OF 1

SCALE	DATE
AS SHOWN	08.09.2023
DWG No.	REV
OS 112	4

NOTE: PARK SIGNAGE SHOP DRAWINGS TO BE APPROVED BY WCC PRIOR TO FABRICATION.



1 PARK SIGNAGE EXAMPLE
BENCHMARKING IMAGE NTS

REV.	DESCRIPTION	DATE	DRN	CHKD
1	PRELIMINARY	12.07.2024	M.M.	R.D.
2	COUNCIL ISSUE	12.07.24	M.M.	R.D.

NOTES

- ALL MEASUREMENTS ARE IN MILLIMETRES UNLESS OTHERWISE STATED.
- REFER WYNDHAM CITY COUNCIL WEBSITE TO ENSURE DRAWINGS ARE THE LATEST REVISION.
- DRAWINGS ARE CONCEPT ONLY AND NOT SPECIFIC TO ANY SITE OR SITE CONDITIONS.
- DRAWINGS CONTAIN TYPICAL ENGINEERING DETAIL FOR INFORMATION ONLY AND WILL REQUIRE PROJECT AND SITE SPECIFIC STRUCTURAL ENGINEERING AND OR SHOP DRAWINGS.
- DRAWINGS WILL BE SUBJECT TO CHANGE THROUGHOUT DESIGN AND CONSTRUCTION PROCESS.
- OVERALL LAYOUT, SIZE AND THEME WILL NOT CHANGE.
- THE DESIGN ASSUMES THAT THE DESIGN WILL BE DEVELOPED AND CONSTRUCTED BY A SUITABLY QUALIFIED CONTRACTOR WITH MINIMUM 10 YEARS RELEVANT INDUSTRY EXPERIENCE.



STANDARD DETAIL - LANDSCAPE
OPEN SPACE FURNITURE
PARK SIGNAGE
SHEET 1 OF 1

STATUS	COUNCIL ISSUE	NOT FOR CONSTRUCTION
SCALE		DATE
AS SHOWN		12.07.2024
DWG No.		REV
OS 113		2